

Lecture 1 – The Electric Power System

Overview. The symmetrical three-phase power system. Electrical power in AC circuits. Measurement of three-phase power Per-unit values of electrical quantities.

Overview

The modern electric power system is a vast interconnected network of components ranging from generators, transformers, transmission lines and a wide variety of “loads”. It is important to analyse both the steady-state and transient behaviour of such a system in order to make valid decisions about the design, operation and protection of such a system. Also, today’s power system is increasingly becoming a mixture of power and communications, with “intelligent” networks being designed and installed all over the world. Combined with the drive towards renewable energy, such a convergence of technologies has rejuvenated the area of power systems.

Early History of Power Systems

| | | |
|------|---|--------------------------------|
| 1880 | Edison starts full-scale manufacture of DC generators and incandescent lamps. | Early history of power systems |
| 1882 | First power stations built by Edison, using 30 kW 110 V DC generators driven by steam engines: January: Holborn Viaduct, London. September: Pearl St, New York City. Supplied 59 customers. Due to the low voltage, the maximum transmission distance was limited to about 1.6 km. | |
| 1884 | Sprague starts manufacture of DC motors. | |
| 1885 | Stanley builds first practical transformer. | |
| 1886 | First AC system in operation in Great Barrington, Massachusetts. Steam engine driving a Siemens 6 kW 500 V single-phase alternator. Power transmitted over a distance of 1.2 km, then transformed down to 100 V. | |
| 1888 | Tesla builds induction and synchronous machines. (3-phase?) | |
| 1889 | First AC line in USA (4 kV, 21 km). (3-phase?) | |
| 1891 | First 3-phase line in Germany (12 kV, 179 km). | |

1.2

Present-Day Power Systems

Present-day systems are universally three-phase AC (reasons to be discussed later), but some large systems incorporate high voltage DC transmission links in special circumstances. Where DC is required for an industrial process, rectifier plant is used.

Generator efficiency improves with size. With present technology the optimum practical output of steam turbine generators for large-scale generation is probably around 600 to 800 MW, and the optimum voltage about 23 kV.

Transmission voltages (long distance) range from 66 kV to 750 kV and higher. High voltage distribution (short to medium distance) voltages range from 2.2 kV to 132 kV, overlapping the transmission range.

Most (except very large) consumers receive power at 400 / 230 V (in Australia).

Frequency for public systems has been standardised to 50 Hz in most of the world, and 60 Hz in the USA.

The early power supply systems typically had a single power (generating) station supplying a multitude of loads. Some small isolated systems today are similar, but large scale present-day public power supply networks have many interconnected power stations, and are therefore more difficult to analyse.

Notation

As, more often than not, we will be dealing with complex, rather than real values, we will use normal upper case letters to denote complex quantities (phasors, impedances, etc.).

The magnitudes, or absolute values, of the complex quantities will generally be indicated by enclosing the upper case letter between vertical bars. There are some exceptions to this rule. The most notable exceptions are:

$$V_{ph} = \text{RMS magnitude of the phase voltage} \quad (1.1a)$$

$$V_{line} = \text{RMS magnitude of the line voltage} \quad (1.1b)$$

$$I_{ph} = \text{RMS magnitude of the phase current} \quad (1.1c)$$

$$I_{line} = \text{RMS magnitude of the line current} \quad (1.1d)$$

Stick to the notation in the exam, or otherwise indicate clearly whether you refer to phasors, peak value, RMS values, instantaneous values, etc. You will lose marks for ambiguous notation.

Values of AC voltage and current (absolute values, as well as real and imaginary components) will be assumed to be RMS (not peak), unless stated otherwise.

For instantaneous values of waveform (voltage, current, power, etc.) we will use lower case letters.

Special margin notes draw attention to some important points.

1.4

The Symmetrical Three-Phase Power System

The Phasor Operator h

Define:

The phasor operator h defined

$$h = -\frac{1}{2} + j\frac{\sqrt{3}}{2} = e^{j\frac{2\pi}{3}} = 1\angle 120^\circ \quad (1.2)$$

Though h is defined as a complex constant, it can also be regarded as an operator which rotates a phasor by 120° anti-clockwise. Similarly, $j = \sqrt{-1}$ is an imaginary constant, but can be regarded as an operator which rotates a phasor by 90° .

Alternative symbols for h , found in textbooks, are 'a' and 'α'.

From the definition of h , we can easily derive the integer powers of h , and some of their combinations:

$$\begin{aligned} h &= 1\angle 120^\circ = \frac{1}{2} + j\frac{\sqrt{3}}{2} & h^* &= 1\angle -120^\circ = -\frac{1}{2} - j\frac{\sqrt{3}}{2} = h^2 \\ h^2 &= 1\angle 240^\circ = -\frac{1}{2} - j\frac{\sqrt{3}}{2} = h^* & (h^2)^* &= h \\ h^3 &= 1\angle 360^\circ = 1\angle 0^\circ = 1 + j0 & h^4 &= h, h^5 = h^2 \\ h^{-1} &= 1\angle -120^\circ = 1\angle 240^\circ = h^2 & h^{-2} &= 1\angle -240^\circ = 1\angle 120^\circ = h \end{aligned} \quad (1.3)$$

The most important relation containing h is:

$$1 + h + h^2 = 0 \quad (1.4)$$

We also have:

$$\begin{aligned} 1 + h = -h^2 &= 1\angle 60^\circ & 1 - h &= \frac{3}{2} - j\frac{\sqrt{3}}{2} = \sqrt{3}\angle -30^\circ \\ 1 + h^2 = -h &= 1\angle -60^\circ & 1 - h^2 &= \frac{3}{2} + j\frac{\sqrt{3}}{2} = \sqrt{3}\angle 30^\circ \end{aligned} \quad (1.5)$$

Some of these relationships are shown below:

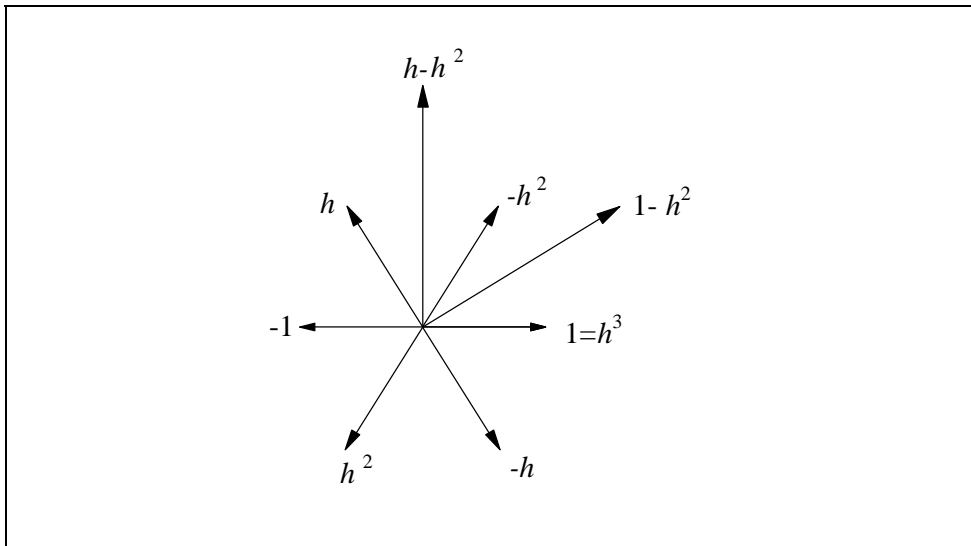

Figure 1.1

1.6

Star-Connected Voltage Source

Consider a simple symmetrical three-phase system, consisting of three voltage sources V_a V_b V_c as shown:

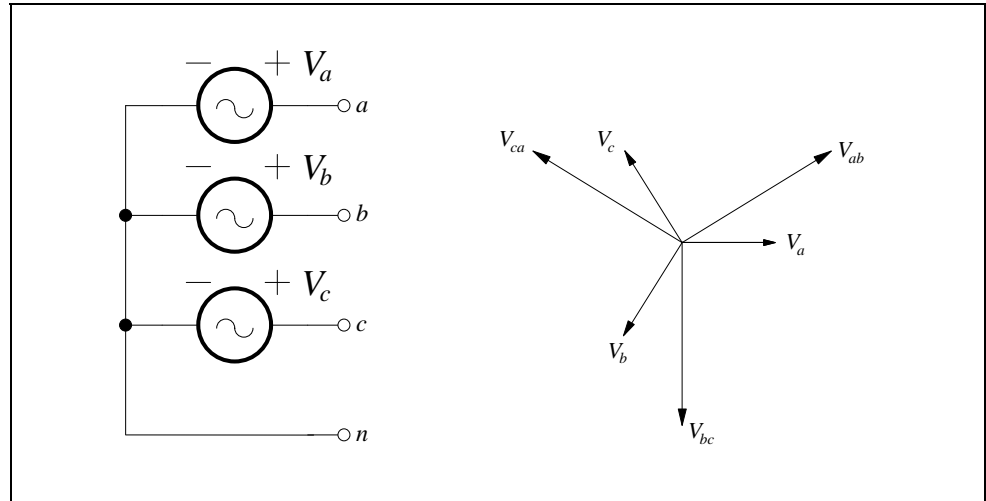

Figure 1.2

The terminals a , b , c are the *line terminals*. The terminal n is the *neutral terminal*. The voltages V_a V_b V_c are the *line-to-neutral voltages*, which are (in the star-connected system) the same as *phase voltages*.

Let these be, in phasor notation:

$$\begin{aligned} V_a &= V_{ph} \angle \theta \\ V_b &= V_{ph} \angle \theta - 120^\circ \\ V_c &= V_{ph} \angle \theta - 240^\circ \end{aligned} \tag{1.6}$$

V_{ph} = RMS magnitude of the phase voltage (positive real value)

The phasors (V_a V_b V_c) are drawn in *clockwise order*. Rotating in the *anticlockwise direction* the phasors will then present themselves in the correct sequence to a stationary observer.

Using the operator h :

$$\begin{aligned} V_a &= V_{ph} \angle \theta \\ V_b &= h^2 V_a \\ V_c &= h V_a \end{aligned} \quad (1.7)$$

The phasor diagram in Figure 1.2 is drawn for $\theta = 0$. The corresponding instantaneous voltages are:

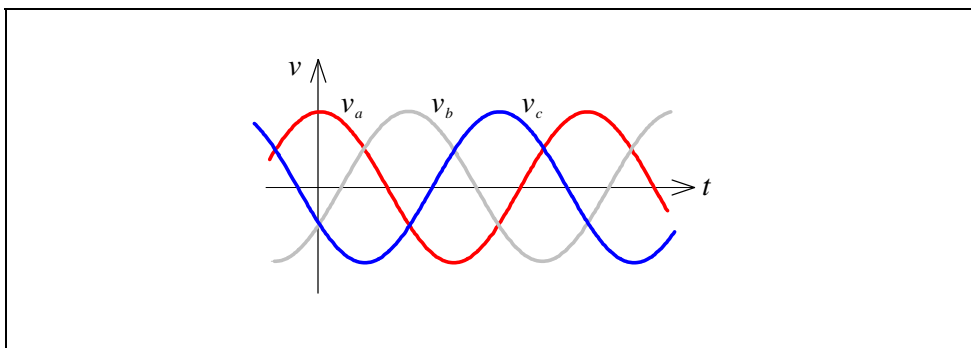

Figure 1.3

with:

$$v_a = \sqrt{2} |V_a| \cos(\omega t) \quad (1.8a)$$

$$v_b = \sqrt{2} |V_a| \cos\left(\omega t - \frac{2\pi}{3}\right) \quad (1.8b)$$

$$v_c = \sqrt{2} |V_a| \cos\left(\omega t - \frac{4\pi}{3}\right) \quad (1.8c)$$

The system is said to have a phase sequence abc . The phases may also be identified by three colours, e.g. red, white, blue. In that case red-white-blue (formerly red-yellow-blue) is the standard phase sequence. Different colours and symbols (e.g. RST) might be used in other parts of the world.

1.8

The line-to-line voltages, measured between the three pairs of line terminals, are:

By convention the nominal voltage of the three-phase system refers to the line-to-line voltage

$$V_{ab} = V_a - V_b = (1 - h^2)V_a = (\sqrt{3}\angle 30^\circ)V_a = V_{ab} \quad (1.9)$$

$$V_{bc} = V_b - V_c = h(h - 1)V_a = (\sqrt{3}\angle 270^\circ)V_a = h^2V_{ab} \quad (1.9b)$$

$$V_{ca} = V_c - V_a = (h - 1)V_a = (\sqrt{3}\angle 150^\circ)V_a = hV_{ab} \quad (1.9c)$$

and:

Voltage magnitudes quoted without qualification usually are line-to-line voltages, or simply "line voltages"

$$|V_{ab}| = |V_{bc}| = |V_{ca}| = \sqrt{3}|V_a| = \sqrt{3}V_{ph} = V_{line} \quad (1.10)$$

V_{line} = RMS magnitude of the line-to-line voltage, usually called (somewhat ambiguously), "the line voltage".

Thus the line-to-line voltages (V_{ab} V_{bc} V_{ca}) have the same sequence as the line-to-neutral voltages (V_a V_b V_c), but their magnitudes are multiplied by $\sqrt{3}$, and they *lead* the corresponding phase voltages by 30° .

Similarly:

$$V_{ac} = V_a - V_c = (1 - h)V_a = (\sqrt{3}\angle -30^\circ)V_a = V_{ac} \quad (1.11)$$

$$V_{ba} = V_b - V_a = (h^2 - 1)V_a = (\sqrt{3}\angle 210^\circ)V_a = h^2V_{ac} \quad (1.11b)$$

$$V_{cb} = V_c - V_b = h(1 - h)V_a = (\sqrt{3}\angle 90^\circ)V_a = hV_{ac} \quad (1.11c)$$

Thus the line-to-line voltages (V_{ac} V_{ba} V_{cb}) also have the same sequence as the line-to-neutral voltages (V_a V_b V_c), but in this case their phase angles *lag* the phase voltages by 30° .

Star-Connected Load

Consider a simple symmetrical three-phase system, with three equal load impedances connected in a star:

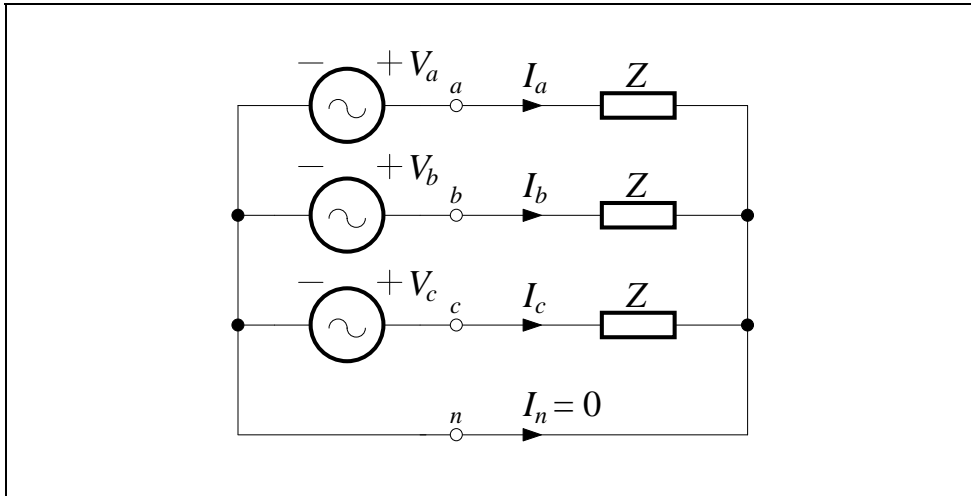

Figure 1.4

The independent voltage sources are as before:

$$\begin{aligned} V_a &= V_{ph} \angle \theta \\ V_b &= h^2 V_a \\ V_c &= h V_a \end{aligned} \quad (1.12)$$

and the three equal load impedances are:

$$Z = R + jX \quad (1.13)$$

1.10

Obviously, the phase currents (identical to line currents in this case) are:

$$\begin{aligned} I_a &= \frac{V_a}{Z} \\ I_b &= h^2 I_a = (1 \angle -120^\circ) I_a \\ I_c &= h I_a = (1 \angle -240^\circ) I_a \end{aligned} \tag{1.14}$$

Thus, once the phase “a” current I_a has been calculated, the other two phase currents can be obtained by rotating the I_a phasor by 120° increments.

Since $1+h+h^2=0$, the phase currents sum to zero. Therefore, the neutral current $I_n=0$, and the neutral connection is redundant. In practice, for reasons to be covered later, it may be either omitted or connected, and we talk of 3-wire and 4-wire systems.

We also have:

$$|I_a| = |I_b| = |I_c| = I_{ph} = I_{line} \quad \text{star connection only} \tag{1.15}$$

I_{ph} = RMS magnitude of the phase current

I_{line} = RMS magnitude of the line current

Delta Connection

Either the sources or the loads (or both) may also be connected in a loop or *delta* formation. This is illustrated below for a delta connected load:

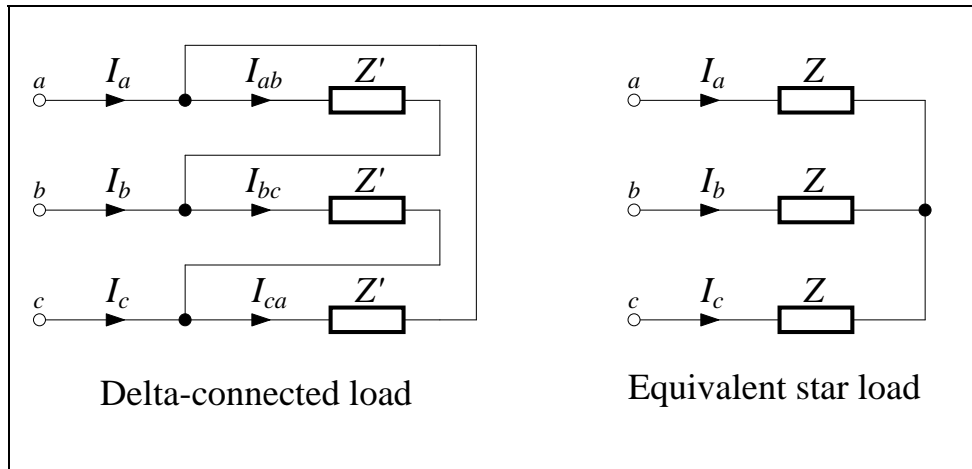

Figure 1.5

For the delta circuit the line-to-line voltages (V_{ab} V_{bc} V_{ca}) are also the phase voltages. Thus $(V_{ph})_{delta} = V_{line}$.

The phase currents are (I_{ab} I_{bc} I_{ca}) with magnitudes of $(I_{ph})_{delta}$. The line currents are (I_a I_b I_c), with magnitudes of $I_{line} = \sqrt{3}(I_{ph})_{delta}$.

For every delta connected circuit there is an *equivalent star* circuit. Because a delta circuit has no neutral connections, the reverse is not necessarily true.

Let (V_a V_b V_c) be the equivalent star phase voltages. Then:

$$|Z'| = \frac{|V_{ab}|}{|I_{ab}|}, \quad |Z| = \frac{|V_a|}{|I_a|} = \frac{|V_{ab}|}{3|I_{ab}|}, \quad \text{therefore } |Z| = \frac{|Z'|}{3} \quad (1.16)$$

We can assume both Z and Z' have the same angle, therefore the equivalent star impedance is:

$$Z = \frac{Z'}{3}$$

(1.17)

To avoid confusion, it is generally best to convert all delta circuits to equivalent star circuits for network

1.12

Coupling Between Phases

In the previous sections we assumed no coupling between the three phase impedances Z (or Z' in case of delta-connected impedances). Now, let us assume that we have a symmetrical passive circuit, so that the self-impedances of the three phases are equal, and the mutual impedances between phases are also equal.

Let:

$$\begin{aligned} Z_s &= \text{self - impedance of each phase} \\ Z_m &= \text{mutual impedance between any pair of phases} \end{aligned} \quad (1.18)$$

then:

$$\begin{bmatrix} V_a \\ V_b \\ V_c \end{bmatrix} = \begin{bmatrix} Z_s & Z_m & Z_m \\ Z_m & Z_s & Z_m \\ Z_m & Z_m & Z_s \end{bmatrix} \begin{bmatrix} I_a \\ I_b \\ I_c \end{bmatrix} = \begin{bmatrix} Z_s I_a + Z_m (I_b + I_c) \\ Z_s I_b + Z_m (I_a + I_c) \\ Z_s I_c + Z_m (I_b + I_a) \end{bmatrix} \quad (1.19)$$

For symmetrical currents, $I_a + I_b + I_c = 0$, therefore:

$$\begin{bmatrix} V_a \\ V_b \\ V_c \end{bmatrix} = (Z_s - Z_m) \begin{bmatrix} I_a \\ I_b \\ I_c \end{bmatrix} = Z \begin{bmatrix} I_a \\ I_b \\ I_c \end{bmatrix} \quad (1.20)$$

Effective impedance defined

where $Z = Z_s - Z_m$ is the effective impedance per phase, or simply “impedance per phase”.

The effective impedance per phase can be measured directly, using three-phase currents, or can be calculated, if we know the self and mutual impedances. When the term “impedance”, without further qualification, is used in three-phase work, the effective impedance per phase is generally implied. *This impedance Z can be used for calculations in the completely symmetrical case only.* Eq. (1.19) is more general: although it assumes symmetrical impedances, it does not assume symmetrical currents.

Electrical Power in AC Circuits

Power in a Single-Phase Circuit

Consider the single-phase network shown below:

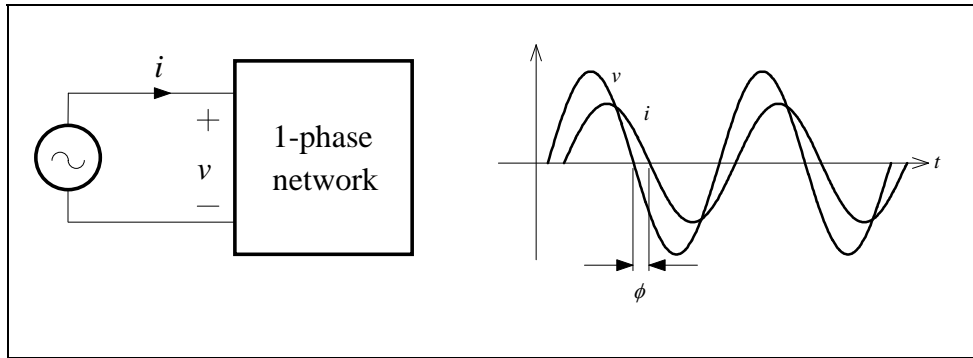

Figure 1.6

Let:

$$\begin{aligned} v &= \sqrt{2}|V|\cos(\omega t + \alpha) \\ i &= \sqrt{2}|I|\cos(\omega t + \beta) \end{aligned} \quad (1.21)$$

and define:

$$\phi = \alpha - \beta \quad (1.22)$$

Then the instantaneous power input to the network is:

$$\begin{aligned} p &= vi \\ &= 2|V||I|\cos(\omega t + \alpha)\cos(\omega t + \beta) \\ &= |V||I|[\cos(\alpha - \beta) + \cos(2\omega t + \alpha + \beta)] \\ &= |V||I|[\cos \phi + \cos(2\omega t + \alpha + \beta)] \end{aligned} \quad (1.23)$$

1.14

P is the average value of p , not the RMS value, which has no useful meaning in this case, despite the widespread (mis)use of the term "RMS power" in the hi-fi industry

The second term oscillates at double the supply frequency, and contributes nothing to the average power, which is:

$$P = |V||I| \cos \phi \quad (1.24)$$

Further expanding Eq. (1.23), using $\cos(A - B) = \cos A \cos B + \sin A \sin B$, we get:

$$\begin{aligned} p &= |V||I| [\cos \phi + \cos(2\omega t + \alpha + \beta)] \\ &= |V||I| [\cos \phi + \cos(2\omega t + 2\alpha) \cos \phi + \sin(2\omega t + 2\alpha) \sin \phi] \\ &= |V||I| \cos \phi [1 + \cos(2\omega t + 2\alpha)] + |V||I| \sin \phi \sin(2\omega t + 2\alpha) \end{aligned} \quad (1.25)$$

Now define the *reactive power*:

Reactive power defined

$$Q = |V||I| \sin \phi \quad (1.26)$$

then:

$$p = P[1 + \cos(2\omega t + 2\alpha)] + Q \sin(2\omega t + 2\alpha) \quad (1.27)$$

The instantaneous power associated with the real and reactive power components is shown below:

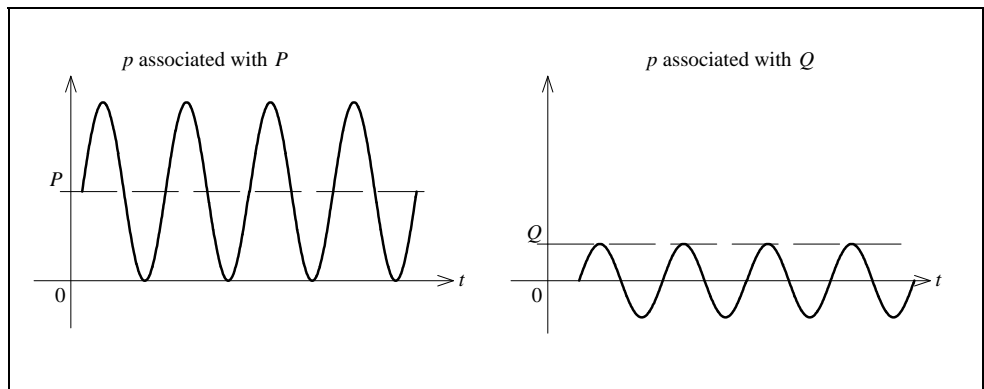

Figure 1.7

Using phasors, we define *complex power*:

$$S = VI^*$$

(1.28) Complex power defined

Corresponding to Eq. (1.21), we have:

$$\begin{aligned} V &= |V| \angle \alpha \\ I &= |I| \angle \beta \\ I^* &= |I| \angle -\beta \end{aligned} \quad (1.29)$$

and we have:

$$\begin{aligned} VI^* &= |V||I| \angle \alpha - \beta \\ &= |V||I| \angle \phi \\ &= |V||I| (\cos \phi + j \sin \phi) \end{aligned} \quad (1.30)$$

Hence the complex power is:

$$S = VI^* = |S| \angle \phi = P + jQ \quad (\text{complex VA}) \quad (1.31)$$

where:

$$\begin{aligned} |S| &= |V||I| = \text{apparent power (VA)} \\ P &= |S| \cos \phi = \text{real power (W)} \\ Q &= |S| \sin \phi = \text{reactive power (var)} \\ \phi &= \text{angle by which the voltage } V \text{ leads the current } I \\ |S|^2 &= P^2 + Q^2 \end{aligned} \quad (1.32)$$

Components of complex power

Real power is also known as active power and average power

1.16

These relationships are illustrated below:

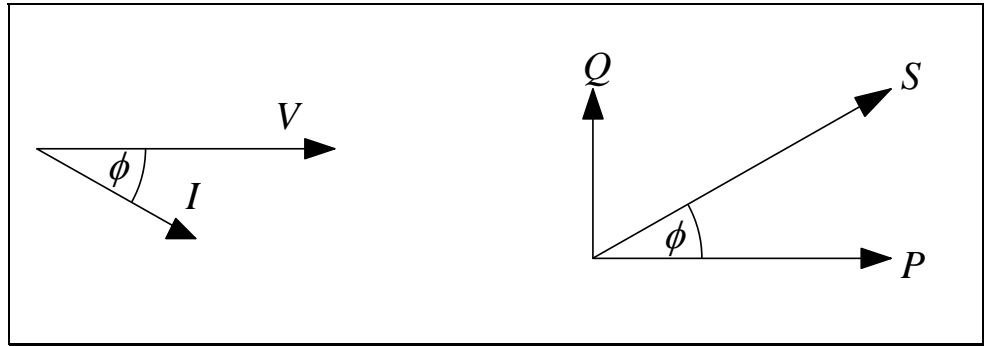

Figure 1.8

If the network (load) has an impedance Z , then $V = ZI$, and:

$$S = VI^* = ZII^* = Z|I|^2 \quad (1.33)$$

If the network (load) has an admittance Y , then $I = YV$, and:

$$S = VI^* = VV^*Y^* = Y^*|V|^2 \quad (1.34)$$

It can be shown that the total complex power $S = P + jQ$ consumed by a network is the sum of the complex powers consumed by all the component parts of the network. This conservation property is not true of the apparent power $|S|$.

Power Factor and Dissipation Factor

We define:

$$\text{Power factor (p.f.)} = \frac{P}{|S|} = \cos \phi$$

(1.35)

Power factor defined

and:

$$\text{Dissipation factor } d = \frac{P}{|Q|} = \tan \delta$$

(1.36)

Dissipation factor defined

where $\delta = 90^\circ - \phi = \text{loss angle}$

Power factor is normally applied to useful power system loads where the ideal is to maximise real power.

Dissipation factor is used with inductors, capacitors, and insulating materials, where the ideal is to minimise real power dissipation.

“Quality factor” = d^{-1} , commonly called “ Q ”, is not to be confused with the reactive power, Q .

1.18

Power in a Three-Phase Circuit

Complex Power

Because the complex power $S = P + jQ$ in any circuit is equal to the sum of the complex powers in parts of the circuit, the complex power of a symmetrical three-phase circuit must be equal to the sum of the powers in each phase. In the case of the symmetrical system this is three times the power in each phase:

Three-phase power for a symmetrical circuit using phase quantities

$$\begin{aligned}P &= 3V_{ph} I_{ph} \cos \phi \\Q &= 3V_{ph} I_{ph} \sin \phi \\S &= 3V_{ph} I_{ph}^*\end{aligned}\tag{1.37}$$

where V_{ph} and I_{ph} are RMS magnitudes of voltage and current per phase, and ϕ is the angle by which the phase voltage leads the phase current.

Eqs. (1.37) converted to use line current and line voltage read:

Three-phase power for a symmetrical circuit using line quantities

$$\begin{aligned}P &= \sqrt{3}V_{line} I_{line} \cos \phi \\Q &= \sqrt{3}V_{line} I_{line} \sin \phi \\S &= \sqrt{3}V_{line} I_{line}^*\end{aligned}\tag{1.38}$$

The apparent power is $|S| = \sqrt{P^2 + Q^2}$ as for the single-phase case.

Instantaneous Power

Consider the simple symmetrical three-phase system shown below:

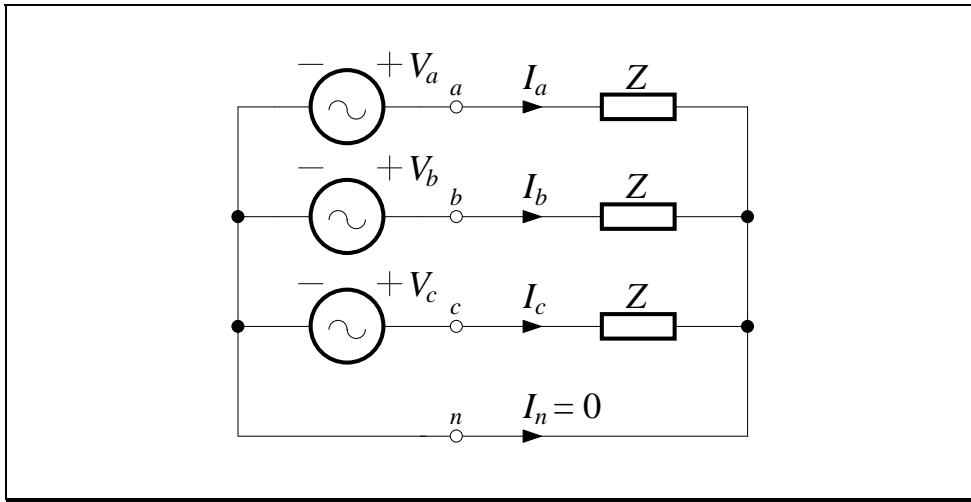

Figure 1.9

Using phase “a” voltage as the time reference, i.e. setting $\alpha = 0$ in Eq. (1.21), we get:

$$\begin{aligned} v_a &= \sqrt{2}V_{ph} \cos(\omega t) & i_a &= \sqrt{2}I_{ph} \cos(\omega t - \phi) \\ v_b &= \sqrt{2}V_{ph} \cos(\omega t - 2\pi/3) & i_b &= \sqrt{2}I_{ph} \cos(\omega t - 2\pi/3 - \phi) \\ v_c &= \sqrt{2}V_{ph} \cos(\omega t - 4\pi/3) & i_c &= \sqrt{2}I_{ph} \cos(\omega t - 4\pi/3 - \phi) \end{aligned} \quad (1.39)$$

The instantaneous power in each phase is:

$$\begin{aligned} p_a &= v_a i_a = 2V_{ph} I_{ph} \cos(\omega t) \cos(\omega t - \phi) \\ p_b &= v_b i_b = 2V_{ph} I_{ph} \cos(\omega t - 2\pi/3) \cos(\omega t - 2\pi/3 - \phi) \\ p_c &= v_c i_c = 2V_{ph} I_{ph} \cos(\omega t - 4\pi/3) \cos(\omega t - 4\pi/3 - \phi) \end{aligned} \quad (1.40)$$

Using $2 \cos A \cos B = \cos(A+B) + \cos(A-B)$, we expand:

$$\begin{aligned} p_a &= v_a i_a = V_{ph} I_{ph} [\cos \phi + \cos(2\omega t - \phi)] \\ p_b &= v_b i_b = V_{ph} I_{ph} [\cos \phi + \cos(2\omega t - 4\pi/3 - \phi)] \\ p_c &= v_c i_c = V_{ph} I_{ph} [\cos \phi + \cos(2\omega t - 2\pi/3 - \phi)] \end{aligned} \quad (1.41)$$

1.20

The total instantaneous power is:

Instantaneous three-phase power for a symmetrical circuit is equal to the average power, and is constant (does not vary with time)!

$$\begin{aligned} p &= p_a + p_b + p_c \\ &= 3V_{ph} I_{ph} \cos \phi \\ &= P \end{aligned}$$

(1.42)

Eq. (1.42) shows that the symmetrical three-phase instantaneous power is constant and equal to the real power. There is no oscillatory term as in a single-phase circuit. The property of constant instantaneous power is not unique to the three-phase system, but applies to poly-phase systems in general.

The constant instantaneous power is a great asset for electrical machines, facilitating smooth power conversion without vibration. With single-phase electromechanical power conversion vibration at double the supply frequency is inevitable.

Measurement of Three-Phase Power

Using Three Wattmeters

Consider the measurement of the total real power in the network shown below:

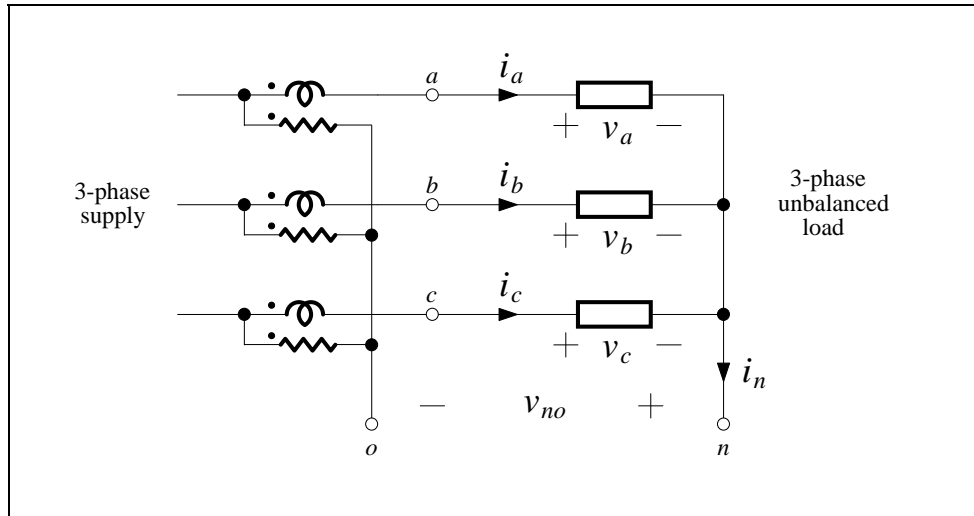

Figure 1.10

Let:

p = total 3-phase instantaneous power supplied to the load

p_m = total instantaneous power seen by the three wattmeters (1.43)

then:

$$\begin{aligned}
 p &= v_a i_a + v_b i_b + v_c i_c \\
 p_m &= (v_a + v_{no}) i_a + (v_b + v_{no}) i_b + (v_c + v_{no}) i_c \\
 &= v_a i_a + v_b i_b + v_c i_c + v_{no} i_n \\
 &= p + v_{no} i_n
 \end{aligned}
 \tag{1.44}$$

Therefore, *the sum of the three wattmeter readings* is the true average power, P , of the load only if $v_{no} i_n = 0$. The method always measures P correctly if points “o” and “n” are bonded, but if $i_n = 0$ (balanced load, or load neutral not connected), then point “o” may be left floating.

1.22

Using Two Wattmeters

From the previous section, if $i_n = 0$, then v_{no} can be any arbitrary value. So connect point “o” in Figure 1.10 to point “b”. Now the “b” phase wattmeter becomes superfluous, as it would always read zero. See the network below:

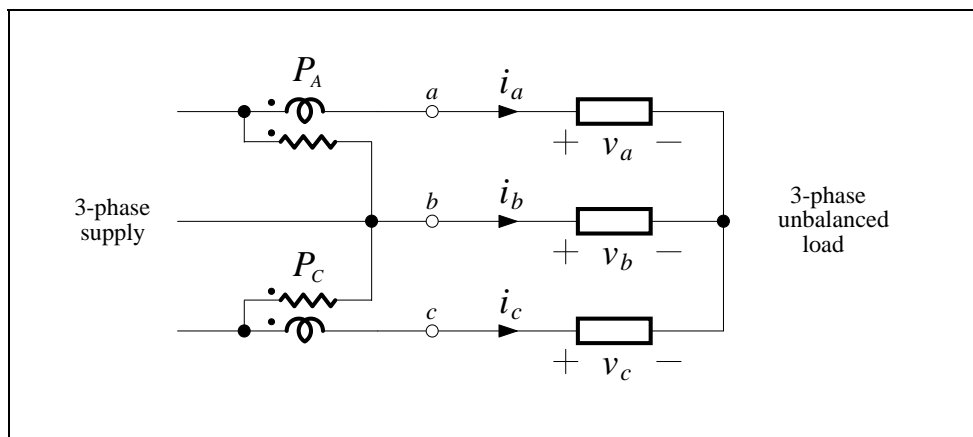

Figure 1.11

The sum of the remaining two wattmeters now gives the true average power, P . Therefore $P = P_A + P_C$ for balanced or unbalanced conditions, if there is no neutral current.

The phasor diagram, drawn for **balanced conditions**, is shown below:

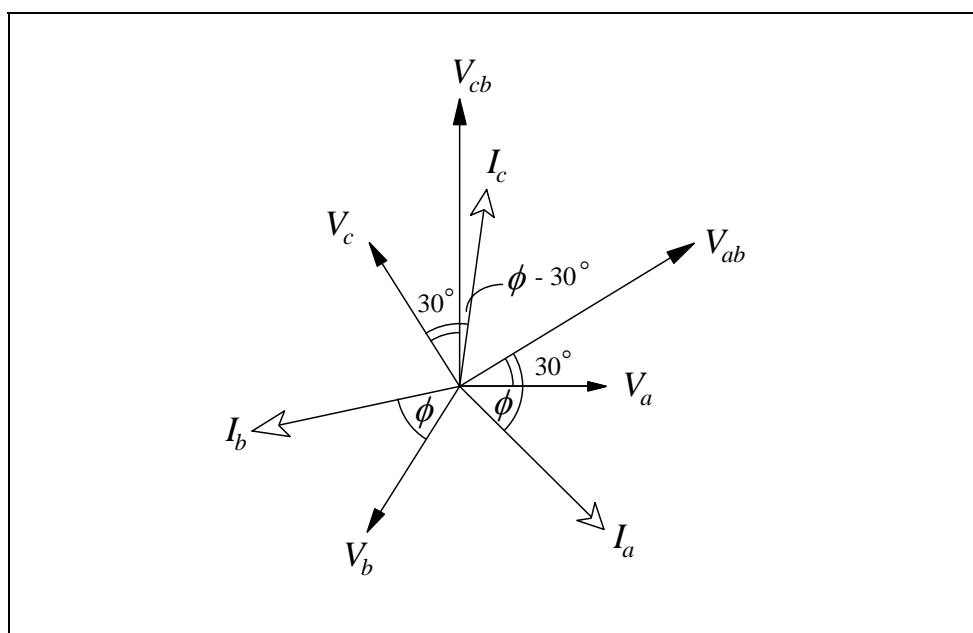

Figure 1.12

The two wattmeter readings are:

$$\begin{aligned} P_A &= |V_{ab}| |I_a| \cos(\phi + 30^\circ) \\ P_C &= |V_{cb}| |I_c| \cos(\phi - 30^\circ) \end{aligned} \quad (1.45)$$

but:

$$\begin{aligned} |V_{ab}| &= |V_{cb}| = \sqrt{3} V_{ph} \\ |I_a| &= |I_c| = I_{ph} \end{aligned} \quad (1.46)$$

hence:

$$\begin{aligned} P_A &= \sqrt{3} V_{ph} I_{ph} \cos(\phi + 30^\circ) \\ P_C &= \sqrt{3} V_{ph} I_{ph} \cos(\phi - 30^\circ) \end{aligned} \quad (1.47)$$

and we obtain:

$$\begin{aligned} P_A + P_C &= 3V_{ph} I_{ph} \cos \phi = P \\ P_C - P_A &= \sqrt{3} V_{ph} I_{ph} \sin \phi = \frac{Q}{\sqrt{3}} \end{aligned} \quad (1.48)$$

Therefore:

| | |
|--|--------|
| $\begin{aligned} P &= P_A + P_C && \text{W} \\ Q &= \sqrt{3}(P_C - P_A) && \text{var} \end{aligned}$ | (1.49) |
|--|--------|

For measurement of Q the method requires balanced conditions. The signs of the wattmeter readings are important. Either P_A or P_C may be negative under some conditions.

1.24

Using One Wattmeter and a Switch

In this case, we have one wattmeter whose “voltage coil” connection is switched between two phases:

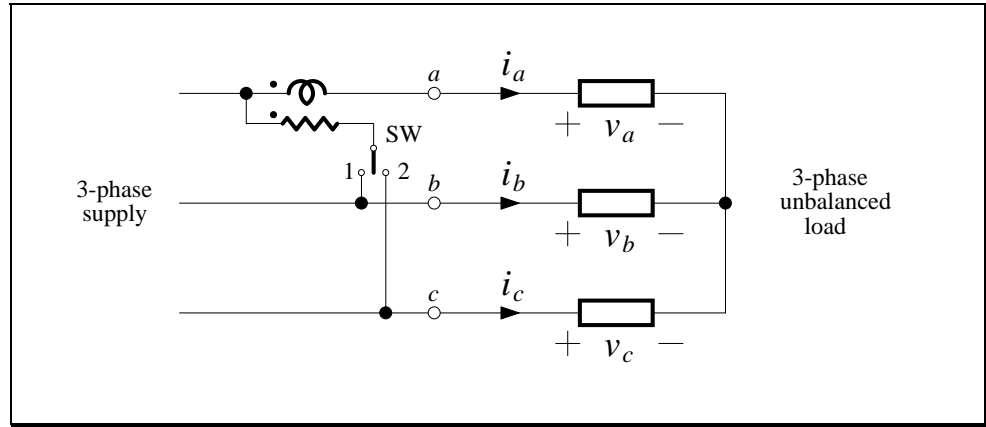

Figure 1.13

P_1 and P_2 are wattmeter readings with switch SW in positions 1 and 2 respectively. The same equations as for the two wattmeters method apply. This method can only be used when the load is steady.

$$\begin{aligned} P &= P_1 + P_2 & \text{W} \\ Q &= \sqrt{3}(P_2 - P_1) & \text{var} \end{aligned} \quad (1.50)$$

Power in Non-Linear Loads

If v and i represent periodic waveforms and current, then they can be written using a compact trigonometric Fourier Series:

$$\begin{aligned} v &= V_{DC} + \sqrt{2} \sum_{n=1}^k V_n \cos(n\omega t + \alpha_n) \\ i &= I_{DC} + \sqrt{2} \sum_{n=1}^k I_n \cos(n\omega t + \beta_n) \end{aligned} \quad (1.51)$$

Note: V_n and I_n here are RMS values, not phasors.

Since:

$$\begin{aligned} \int_0^{2\pi} \cos(nx + \alpha) \cos(mx + \beta) dx &= 0 && \text{if } m \neq n \\ &= \pi \cos(\alpha - \beta) && \text{if } m = n \end{aligned} \quad (1.52)$$

then:

$$P = \frac{1}{T_0} \int_0^{T_0} v i dt = P_{DC} + \sum_{n=1}^k P_n \quad (1.53)$$

where:

$$\begin{aligned} P_n &= V_n I_n \cos(\alpha_n - \beta_n) \\ &= \text{power in the } n\text{-th harmonic} \end{aligned} \quad (1.54)$$

If the supply voltage is sinusoidal, and the supply impedance is low, so that the harmonic current taken by the non-linear load does not cause significant distortion of the supply voltage, then the only power applied to the load is the first harmonic (fundamental frequency). i.e. only the fundamental component of the current is relevant to the power input to the load. Higher harmonic powers do not exist.

If both voltage and current are distorted, then Eq. (1.53) must be used to obtain the total power P .

1.26

Summary

- Three-phase AC power systems developed rapidly and are now standard around the world.
- A symmetrical three-phase circuit can be analysed as a single-phase circuit. Delta connections can be converted to star connections to facilitate this analysis.
- Real power in a three-phase AC circuit is given by $P = 3V_{ph}I_{ph} \cos\phi$.
- Reactive power in a three-phase AC circuit is given by $Q = 3V_{ph}I_{ph} \sin\phi$.
- Complex power in a three-phase AC circuit is given by $S = 3V_{ph}I_{ph}^*$.
- Power factor is a measure of how closely a load delivers maximum real power.
- Dissipation factor is a measure of how closely a load presents itself as lossless.
- The instantaneous power in a symmetrical three-phase system is equal to the average power, $p = P$. This facilitates smooth power conversion.
- Three-phase real power can be measured using just two wattmeters, regardless of load unbalance, source unbalance, and the waveform of the periodic source. The measurement of reactive power requires the system to be balanced.
- If voltage and / or current are not sinusoidal, we calculate the total power by considering the power in each harmonic.

References

Carmo, J.: *Power Circuit Theory Notes*, UTS, 1994.

Truupold, E.: *Power Circuit Theory Notes*, UTS, 1993.

Exercises

1.

Evaluate the following expressions in polar form:

(a) $h^2 - 1$ (b) $1 - h - h^*$ (c) $2h^2 + 3 + 2h$ (d) jh^*

The symmetrical
three-phase power
system

2.

For the delta connected load in Figure 1.5, prove that:

$$I_a = (\sqrt{3} \angle \alpha) I_{ab} \quad I_b = (\sqrt{3} \angle \alpha) I_{bc} \quad I_c = (\sqrt{3} \angle \alpha) I_{ca}$$

and find the value of α .

Draw a phasor diagram of the six currents and six voltages, assuming a resistive load.

3.

For the circuit below, calculate:

- (i) Magnitudes of all currents.
- (ii) Line voltage at terminals A, B, C.

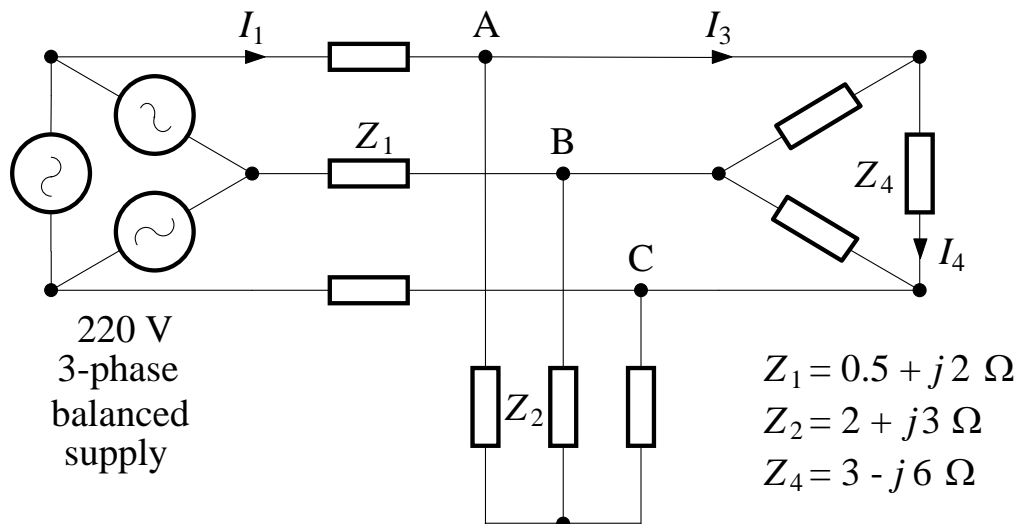

1.28

Electrical power in
AC circuits

4.

A capacitor is required to generate 250 kvar at 6.35 kV, 50 Hz. Calculate:

- (i) The value of the capacitance
- (ii) Maximum energy stored in the capacitor.

5.

Show that for a network of two impedances the complex power input to the network equals the sum of the complex powers absorbed by each impedance, when:

- (i) the impedances are in series
- (ii) the impedances are in parallel

6.

A high voltage withstand test is to be applied to the stator winding to ground insulation of a 660 MW turbo-generator. The capacitance to earth of the winding (the “test object”) is 273 nF. The specified test voltage is 48 kV, 50 Hz. The dissipation factor of the insulation varies with voltage, but is expected to be 40 mW/var at 48 kV.

- (a) Calculate the real and reactive power output of the HV testing transformer used to provide the test voltage.
- (b) An alternative test circuit uses a variable HV reactor L in series with the test object C . The reactor is adjusted for resonance at 50 Hz. The dissipation factor of the reactor is estimated to be 30 mW/var. Determine:

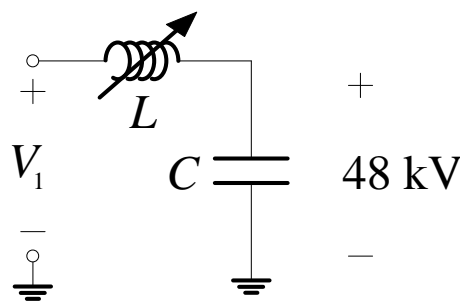

- (i) The reactance of the reactor.
- (ii) Power (real and reactive) absorbed by the reactor.
- (iii) Power input to the circuit.
- (iv) Input voltage $|V_1|$ required.

7.

Two single-phase generators are connected back to back via an inductor (reactance = 5Ω). The emfs of the generators are as shown, and their internal impedances are considered negligible.

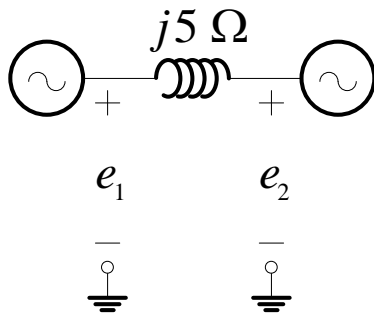

$$e_1 = 100\sqrt{2} \cos(100\pi) \text{ V}$$

$$e_2 = -100\sqrt{2} \sin(100\pi - \pi/3) \text{ V}$$

Determine the watts and vars supplied or received by each component of the network.

8.

For the circuit in Exercise 3, calculate the complex power supplied to the total load from the terminals A, B, C.

9.

A 3-phase transmission circuit has an impedance per phase of $5 + j35 \Omega$. The load at the receiving end consumes 600 kW at unity p.f. and 13.2 kV (line voltage). Calculate sending end voltage magnitude, real, reactive and apparent power.

10.

A 3-phase transmission line has an impedance per phase of $5 + j60 \Omega$. At the sending end the input is 210 MW, 30 Mvar at 220 kV. Find the power and voltage at the receiving end.

1.30

11.

A 3-phase generator supplies a load via two parallel circuits A and B, with impedances $j0.7\ \Omega$ and $j1.3\ \Omega$ respectively. The load on the generator is 30 MVA at 0.8 lagging power factor, and a terminal voltage of 11 kV. Find the complex power input and output for each circuit A and B.

12.

A resistor R is connected to lines “a” and “b” of a symmetrical 3-phase supply. It is suggested that the loading of the supply can be balanced by connecting a reactor jX across lines “a” and “c”, and a capacitor $-jX$ across “b” and “c”.

- (a) Verify that the suggestion is valid, and find the required ratio X/R
- (b) Draw an equivalent star circuit (with component values) for the composite load.

12.

Measurement of
three-phase power

For the “one wattmeter and a switch” method of measuring three-phase power, draw a phasor diagram and prove that $P = P_1 + P_2$ and $Q = \sqrt{3}(P_2 - P_1)$. Give the total watts and vars respectively.

13.

It is possible to use a single wattmeter to measure vars in a symmetric three-phase circuit. Draw a circuit to show how this can be done, and find the value of the calibration constant by which the wattmeter reading has to be multiplied to obtain total vars. (Hint: Inspect the phasor diagram, and connect the wattmeter so that it would read zero when the p.f. = 1.)